

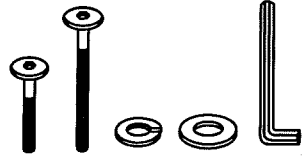
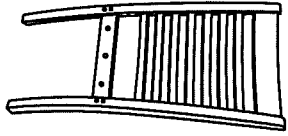

# Assembly Instructions

C1-VT452S - -G , C1-AP452S - -G , C1- ES340SN --X ,  
C1- SF452S --C

## LADDERBACK SIDE CHAIR PARTS LIST

PART NO	FIGURE	DESCRIPTION	Q'TY
C1-VT452S-01 C1-AP452S-01 C1-ES340S-01 CI-SF452S-01		Hardware Bag	1 Pce
C1-VT452S-02 C1-AP452S-02 C1-ES340S-02 CI-SF452S-02		Chair Back	1 Pce
C1-VT452S-03 C1-AP452S-03 C1-ES340S-03 CI-SF452S-03		Wood Seat	1 Pce
C1-VT452S-04 C1-AP452S-04 C1-ES340S-04 CI-SF452S-04		Seat Frame	1 Pce
C1-VT452S-05 C1-AP452S-05 C1-ES340S-05 CI-SF452S-05		Front Leg (Left / Right)	2 Pcs

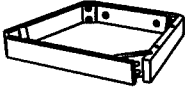
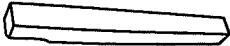
C1-VT452S-02  
C1-AP452S-02  
C1-ES340S-02  
CI-SF452S-02

C1-VT452S-03  
C1-AP452S-03  
C1-ES340S-03  
CI-SF452S-03

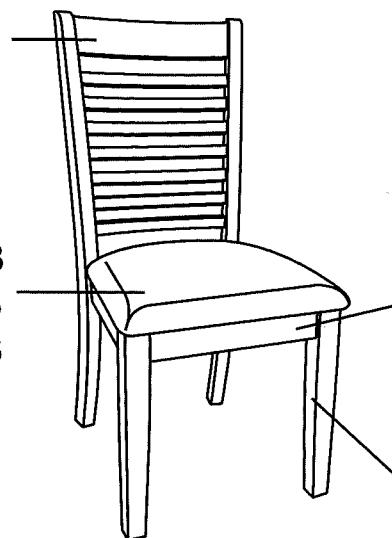





C1-VT452S-04  
C1-AP452S-04  
C1-ES340S-04  
CI-SF452S-04

C1-VT452S-05  
C1-AP452S-05  
C1-ES340S-05  
CI-SF452S-05

# Assembly Instructions

C1-VT452S - -G , C1-AP452S - -G , C1- ES340SN --X ,  
C1- SF452S --C  
**LADDERBACK SIDE CHAIR**

## Hardware List :

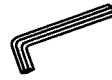
				
M6x40mm JCBC Bolt 2 pcs	M6x70mm JCBC Bolt 8 pcs	M6x13mm Lock Washer 10 pcs	M6.5x16.5mm Flat Washer 10 pcs	Allen Key 1 pce

## ASSEMBLY:

- Position the Chair Back on a soft surface such as a carpet. Place the Seat Frame (Cushion is pre- attached to the seat frame in assembly) on to the middle rail of the Chair Back with the dowel fully inserted into the pre-drilled hole.
  - Insert **70mm JCBC Bolt** through a **Lock Washer** and a **Flat Washer** into the pre- drilled holes on the rear corner block of the seat frame.
  - Insert the **40mm JCBC Bolt** through a **Lock Washer** and a **Flat Washer** through the rear pre-drilled holes on the seat frame.
- Insert the **70mm JCBC Bolt** through a **Lock Washer**, a **Flat Washer** and the pre-drilled holes of Corner Block into the pre-drilled holes on the Front Leg, use the provided **Allen Key**. But do not fully tighten the bolts yet.

### STEP 1

(Fig.1)

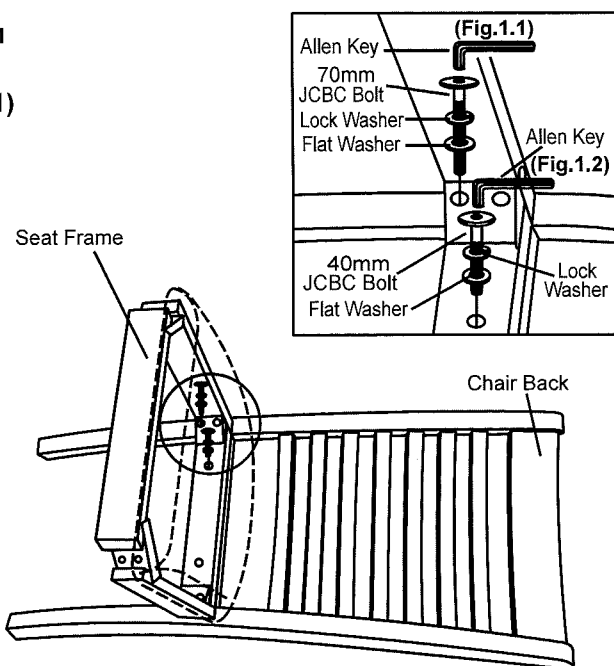

### STEP 2

Assemble front leg as shown

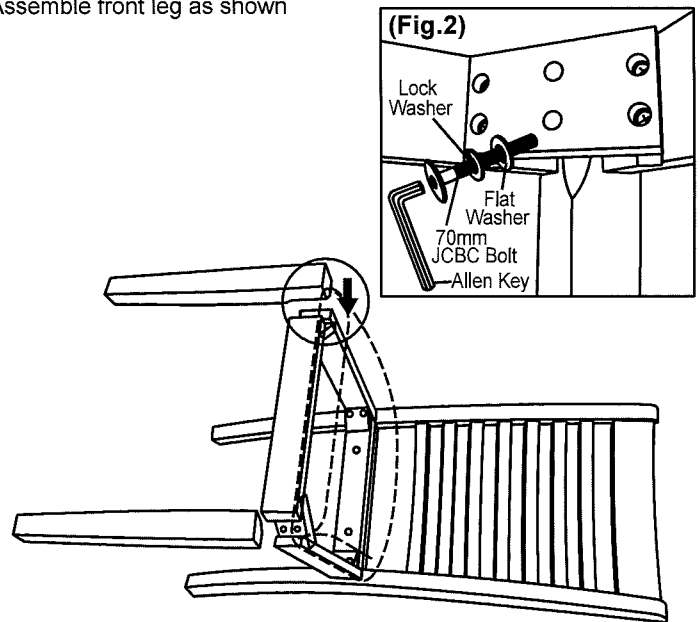

### STEP 3

Turn the chair to standing position. Check it's balance and tighten all screw and bolts to complete the assembly.

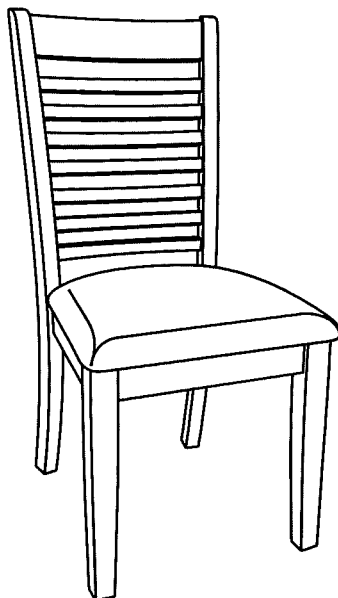

#### IMPORTANT NOTE :

~ Please keep all hardware out of the reach of children.

#### CARE INSTRUCTION

~ Be sure to use the same type of polish consistently. Your furniture will appear cloudy or streaky if oil based or wax based polishes are interchanged.  
~ Spray your furniture surface evenly. Wipe in a circular motion with a soft clean cloth.

# ASSEMBLY INSTRUCTIONS SUPPLEMENT

## Chair leveling procedures:

To make the assembly process easy and efficient, please read the entire instruction sheet prior to beginning the assembly of the chair. Make sure all the hardware listed is included. To properly assemble the chair, none of the bolts should be fully tightened until all the components are attached to the chair. This will allow an opportunity to level the chair and prevent any unnecessary "rocking".

## Note :

Most floors have slight irregularities that can affect chair leveling. If your chair is uneven when placed in its desired locations, perform the following steps

1. Loosen front legs to finger tight.
2. Extend both front legs downward to their fullest length.
3. Gently push downward on the front edge of the seat until all four legs rest on the floor.
4. Re-tighten all bolts and nuts.

## Additional Note:

During normal use, the bolts and nuts should periodically be tightened.