

WINNERS ONLY®



ASSEMBLY INSTRUCTIONS

PROD. NO : C1-VN148BN- -X



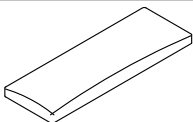
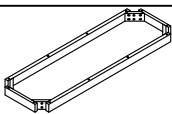
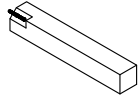

Thank you for purchasing this quality product . Be sure to check all packaging material carefully for small parts that may have come loose inside the carton during shipment .

"Hardware is attached underneath the seat bottom"

Components List :

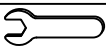
NO	DESCRIPTION	SKETCH	QTY
A	Cushion Seat		1pc
B	Seat Frame		1pc
C	Legs		4pcs
D	Plastic Glide		4pcs

Hardware List :

NO	DESCRIPTION	SIZE	SKETCH	QTY
1	Wrench	12x75 mm		1pc
2	Hex-Nut	5/16"		8pcs
3	Spring Washer	5/16" x Ø12		8pcs
4	Flat Washer	5/16" x Ø19		8pcs

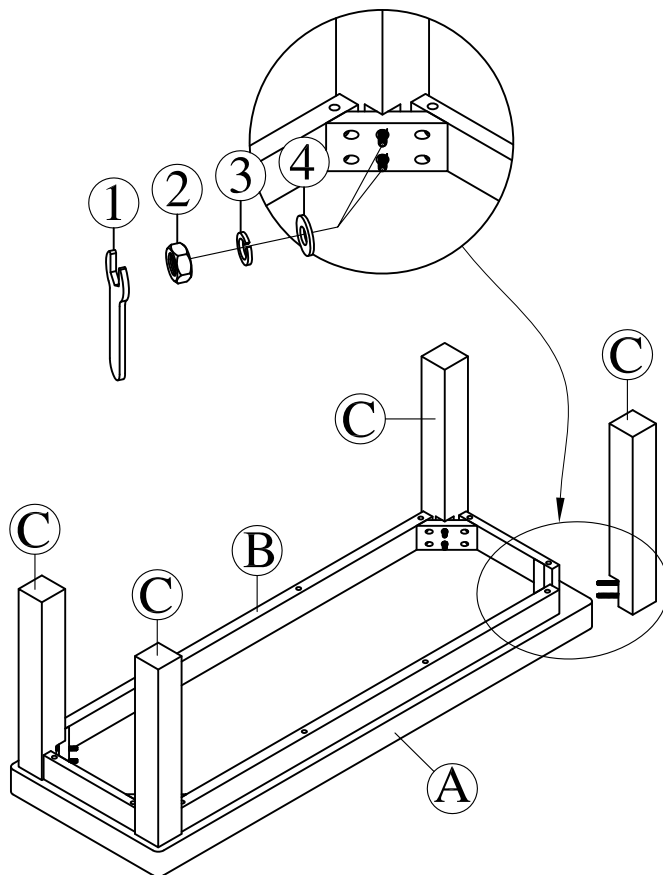

Reminders

1. Use only the hardware supplied.
2. Once the chair is finished, level and tighten all the bolts.
3. Do not over-tighten bolts.
4. This item may require periodic tightening.

NOTE :

1. Hardware pack is located underneath the Cushion Seat (A).

Step 1: Place the Cushion Seat (A) and Seat Frame (B) up side down on the floor with a piece of cloth or carpet underneath to prevent the finish from scratching. Attach the Leg (C) to the Seat Frame (B) and secure with Flat Washer (4), Spring Washer (3) and Hex-Nut (2). Tighten Hex-Nut (2) with Wrench (1). Repeat this step for the rest of the legs.

Assembly is now complete

Thank you for purchasing this product.

