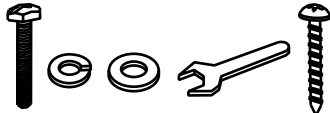
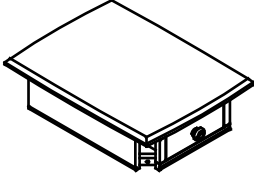
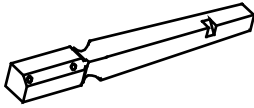
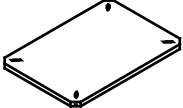

Assembly Instructions

T2-VT100E--G,T2-SF100E--C

END TABLE

PARTS LIST

PART NO	FIGURE	DESCRIPTION	QTY
T2-VT100E-01, T2-SF100E-01		Hardware Bag	1 pce
T2-VT100E-13, T2-SF100E-13		Table Top	1 pce
T2-VT100E-07, T2-SF100E-07		Legs	4 pcs
T2-VT100E-22, T2-SF100E-22		Fixed Shelf	1 pce

IMPORTANT NOTE : Please keep all hardware parts out of the reach of children.

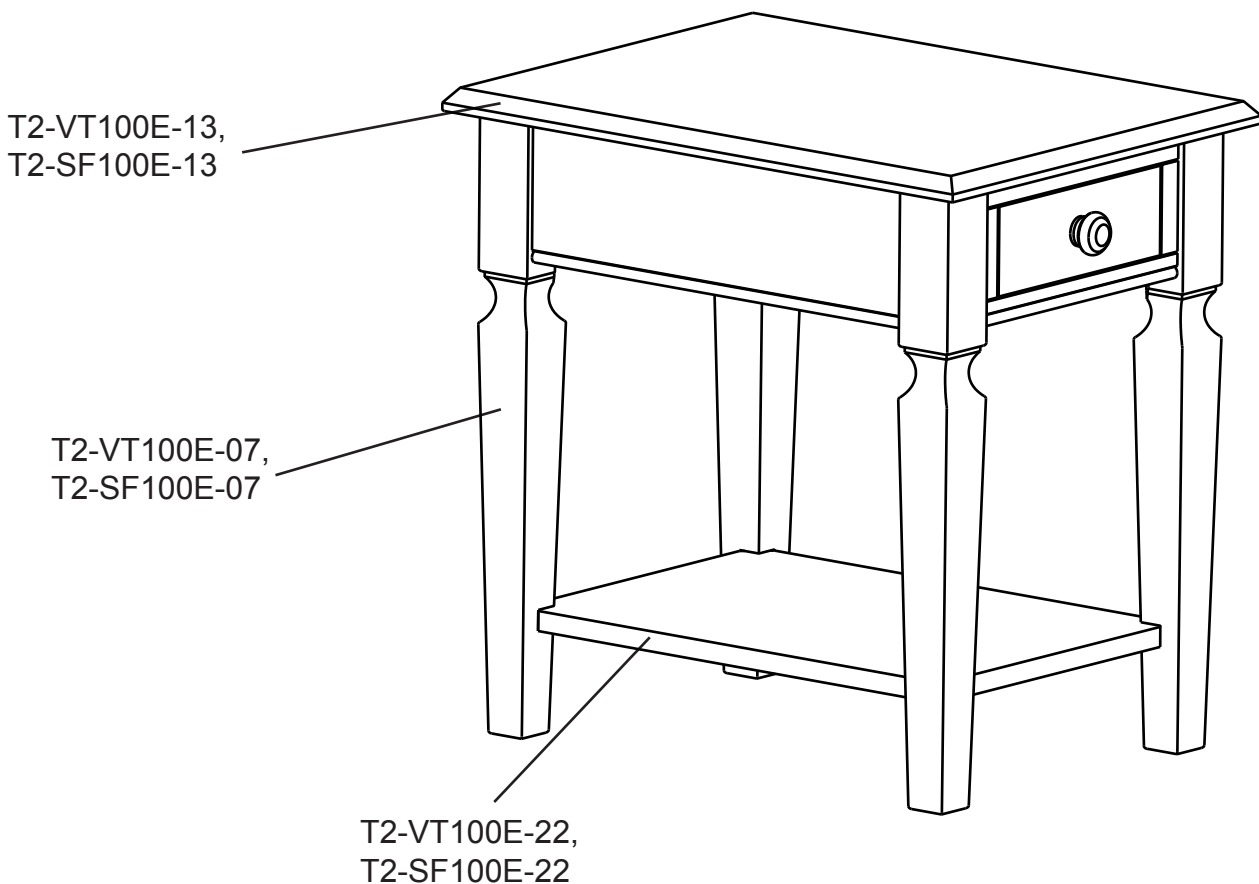

Assembly Instructions





T2-VT100E--G,T2-SF100E--C

END TABLE

Reminders :

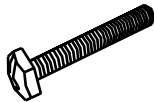
Two people are needed for assembly.
Use only hardware supplied.
Do not over tighten bolts.
This item may require periodic tightening.

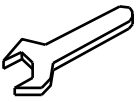
HARDWARE PART :

				
Hex Bolt 8 pcs	Lock Washer 8 pcs	Flat Washer 8 pcs	Wrench 1 pc	Pan Head Screw 4 pcs

ASSEMBLY :

STEP 1

Pull out the Drawer Box as shown and Turn the Table Top upside down on a protective surface such as carpet or other soft material. Use **Flat Washer**, **Lock Washer**, **Hex Bolt** and **Wrench**, to attach three legs randomly to the table top, do not fully tighten yet. Insert the fixed shelf into the legs as shown in the diagram.

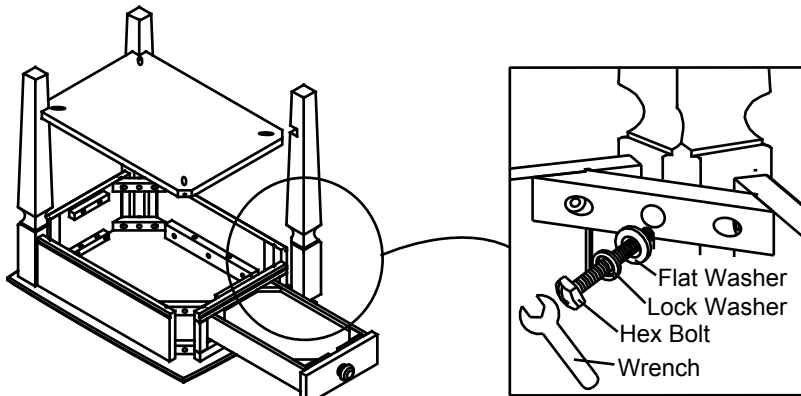

STEP 2

Insert the Fixed Shelf into three legs, insert the last leg to the corner of apron frame and bottom Fixed Shelf. Then tighten with **Flat Washer**, **Lock Washer** and **Hex Bolt** using the **Wrench** provided. And fix the Fixed shelf by insert and tighten the Pan Head Screw using the screw-driver (Not provided).

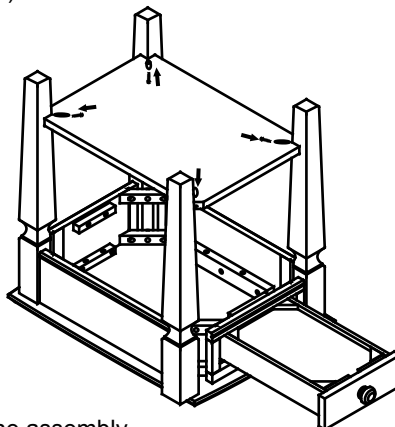

STEP 3

Check its balance and tighten all bolts to complete the assembly.

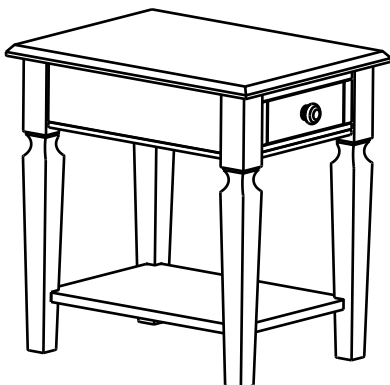

IMPORTANT NOTE :

~ Please keep all hardware out of the reach of children.

CARE INSTRUCTION

~ Be sure to use the same type of polish consistently. Your furniture will appear cloudy or streaky if oil based or wax based polishes are interchanged.
~ Spray your furniture surface evenly. Wipe in a circular motion with a soft clean cloth.