

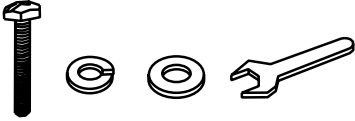





Assembly Instructions

A1-SF148B / A1-ES148B
RTA SERVER WITH 2 DRAWERS & DOORS

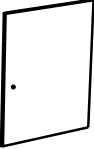
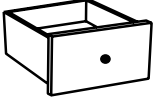
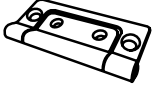
PARTS LIST

PART NO	FIGURE	DESCRIPTION	QTY
A1-SF148B-01 / A1-ES148B-01		Hardware Bag	1 pce
A1-SF148B-02 / A1-ES148B-02		Back Panel	1 pce
A1-SF148B-04 / A1-ES148B-04		Door	2 pcs
A1-SF148B-05 / A1-ES148B-05		Drawer	2 pcs
A1-SF148B-08 / A1-ES148B-08		Hinges	4 pcs
A1-SF148B-10 / A1-ES148B-10		Iron Knob	4 pcs
A1-SF148B-11 / A1-ES148B-11		Legs	4 pcs
A1-SF148B-16 / A1-ES148B-16		Top Panel	1 pce
A1-SF148B-21 / A1-ES148B-21		Magnet Catch	2 pcs





Assembly Instructions

A1-SF148B / A1-ES148B

RTA SERVER WITH 2 DRAWERS & DOORS

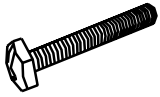
HARDWARE PARTS :

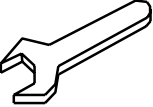
			
Hex Bolt 8 pcs	Lock Washer 8 pcs	Flat Washer 8 pcs	Wrench 1 pc

ASSEMBLY :

STEP 1

Turn the server top upside down on a protective surface such as carpet or other soft material. Insert the three legs first of four legs to corner of server top, then insert the **Flat Washer**, **Lock Washer**, **Hex Bolt** using the **Wrench** but do not fully tighten yet. Install the bottom shelf panel to the legs as shown in the diagram, then install the leg fourth.

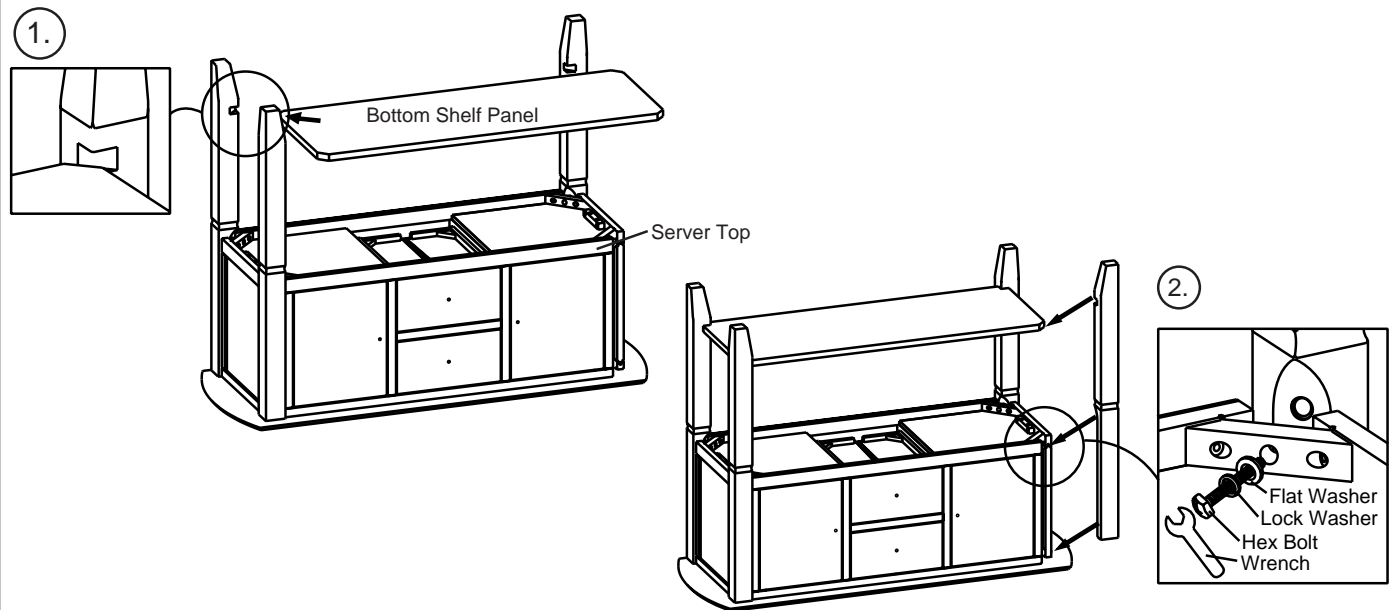

STEP 2

Set the server upright on its legs. Unscrew the knob from the back of the drawer and door. Then install the knob onto the front of the drawer and door, as shown in the diagram. Check its balance and tighten all bolts to complete the assembly.

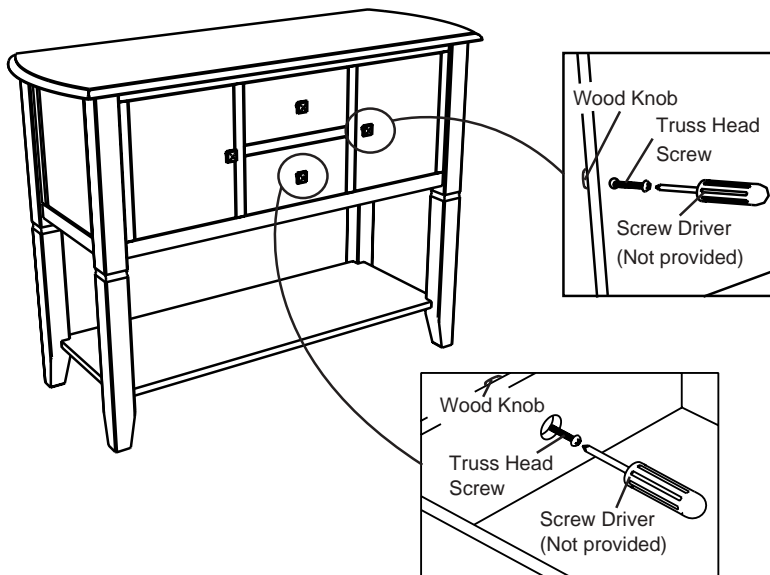

CARE INSTRUCTION

- ~ Be sure to use the same type of polish consistently. Your furniture will appear cloudy or streaky if oil based or wax based polishes are interchanged.
- ~ Spray your furniture surface evenly. Wipe in a circular motion with a soft clean cloth.