

# ASSEMBLY INSTRUCTION

# ITEM : AVALON, QUEEN BED

## HARDWARE LIST

ITEM	DESCRIPTION	QTY
A	JCBB SCREW M 6 x 60	3 pcs
B	SPRING WASHER	3 pcs
C	FLAT WASHER	3 pcs
D	ALLEN KEY M4	1 pc
E	ALLEN KEY M5	1 pc
F	SCREW M4 X 30 mm.	28 pcs
G	SCREW M4 X 16 mm.	14 pcs
H	L- BRACKET	1 pc

## PART LIST

PART / DESCRIPTION	QTY	PART / DESCRIPTION	QTY
HEADBOARD	1 pc	MATTRESS SLAT	14 pcs
FOOTBOARD	1 pc	CENTER SUPPORT	1 pc
SIDE RAIL	2 pcs	CENTER LEG	3 pcs

CAUTIONS : Hardware are to kept out of reach from children.

### STEP 1

Attach " LEG " to the " BODY " as arrow shown , assembly with hardware " G " by using " screw driver ". (DO NOT FULLY TIGHTEN THE SCREW UNTIL ALL ARE IN PLACE)

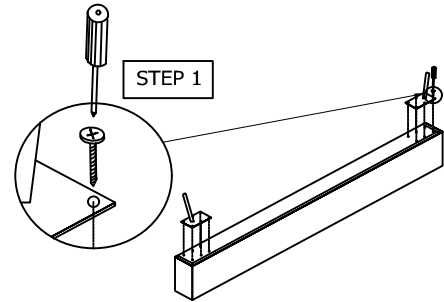

### STEP 2

Remove the "screw" on bracket of HEADBOARD & FOOTBOARD , assembly the SIDE RAIL to HEADBOARD or FOOTBOARD with fix back the existing "screw" to the existing bracket insertion hole.

### STEP 2

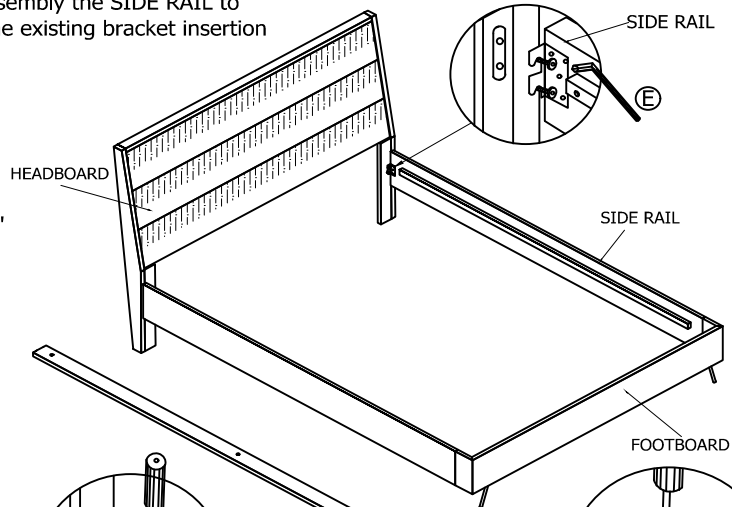

### STEP 3

Attach L- BRACKET onto the CENTER SUPPORT , fix the L-BRACKET with hardware "G" by using screw -driver.

### STEP 4

Attach all mattress slat onto the SIDE RAIL , attach hardware "A","B" and "C" by using ALLEN KEY "D" to assembly the CENTER LEG thru the pre-drilled hole on MATTRESS SLAT and CENTER SUPPORT .

### STEP 5

Lastly, fix the mattress slat with hardware "F" thru pre-drilled hole by using screw-driver. (NOT INCLUDED)

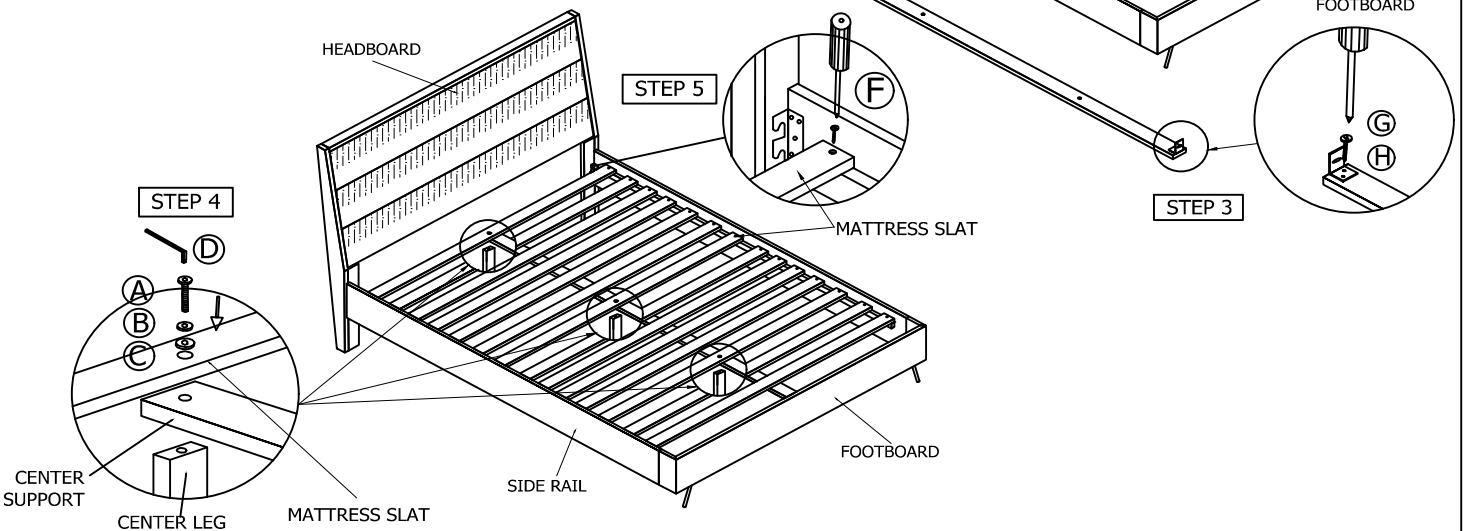

NOTE : ONE BED TOTAL 4 CARTONS ( HEADBOARD ,FOOTBOARD , SIDE RAIL & WOODEN BASE )

MADE IN MALAYSIA