





Assembly Instructions

C1-DT101S--E

3 SPLATS BACK SIDE CHAIR

HARDWARE PARTS :

				
(Short) JCBC Bolt 2 pcs	(Long) JCBC Bolt 8 pcs	Lock Washer 10 pcs	Flat Washer 10 pcs	Allen Key 1 pce

ASSEMBLY:

- Position the chair back on a soft surface such as a carpet. Place the Box system assembly (Cushion is pre-attached to the seat frame in assembly) on to the middle rail of the chair back with the dowel fully inserted into the pre-drilled hole.
 - 1.1 Insert **JCBC Bolt (Long)** through a **Lock Washer** and a **Flat Washer** into the pre-drilled holes on the apron frame at rear corners.
 - 1.2. Insert the **JCBC Bolt (Short)** through a **Lock Washer** and a **Flat Washer** into the pre-drilled holes on the apron frame at rear rail.
2. Insert the **JCBC Bolt (Long)** through a **Lock Washer**, a **Flat Washer** and the pre-drilled holes of corner block into the pre-drilled holes on the front leg, tighten the **JCBC Bolt** with **Allen Key** provided.

STEP 1

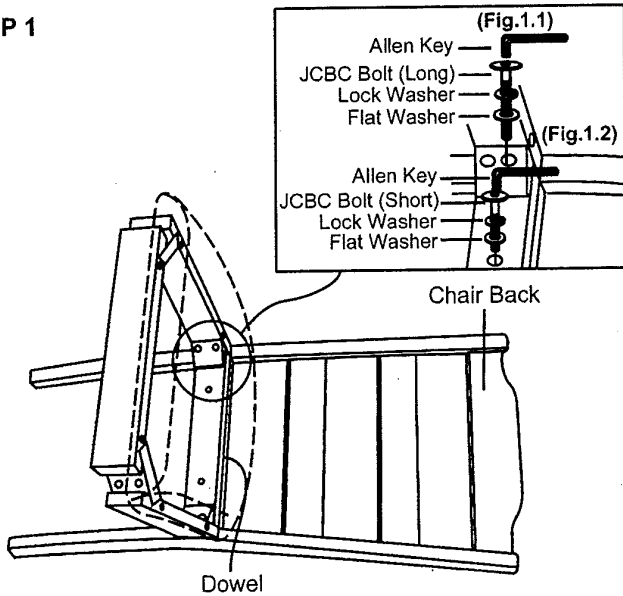

STEP 2

Assemble front leg as shown.

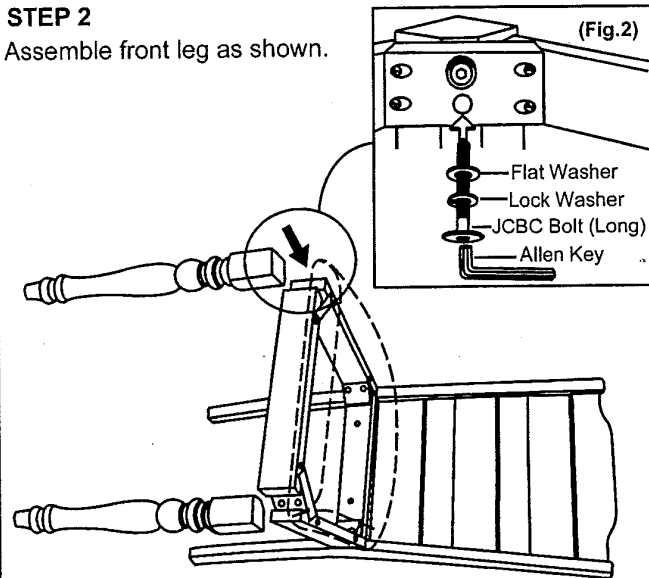

STEP 3

Turn the chair upright. Check its balance and tighten all screws and bolts to complete the assembly.

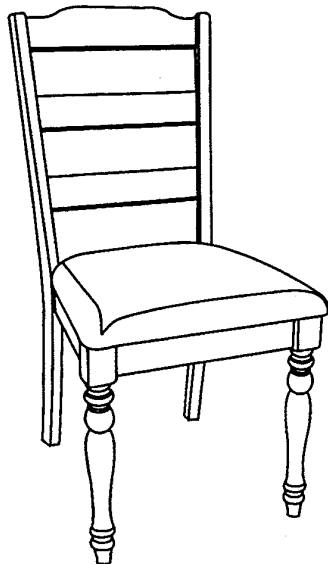





CARE INSTRUCTION

- ~ Be sure to use the same type of polish consistently. Your furniture will appear cloudy or streaky if oil based or wax based polishes are interchanged.
- ~ Spray your furniture surface evenly. Wipe in a circular motion with a soft clean cloth.

Assembly Instructions

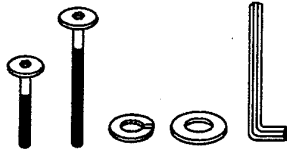
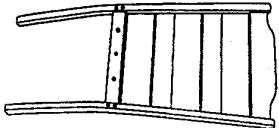
C1-DT101S--E
3 SPLATS BACK SIDE CHAIR

PARTS LIST

PART NO	FIGURE	DESCRIPTION	Q'TY
C1-DT101S--E-01		Hardware Bag	1 Pce
C1-DT101S--E-02		Chair Back	1 Pce
C1-DT101S--E-03		Cushion seat	1 Pce
C1-DT101S--E-04		Seat Frame	1 Pce
C1-DT101S--E-05		Front Leg (Right)	1 Pce
C1-DT101S--E-06		Front Leg (Left)	1 Pce

