

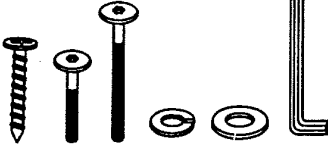

Assembly Instructions

C1-DT105S--E
SLAT BACK SIDE CHAIR

PARTS LIST

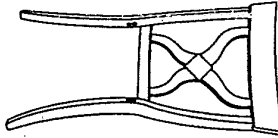

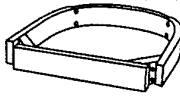
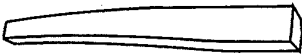
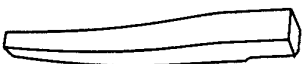
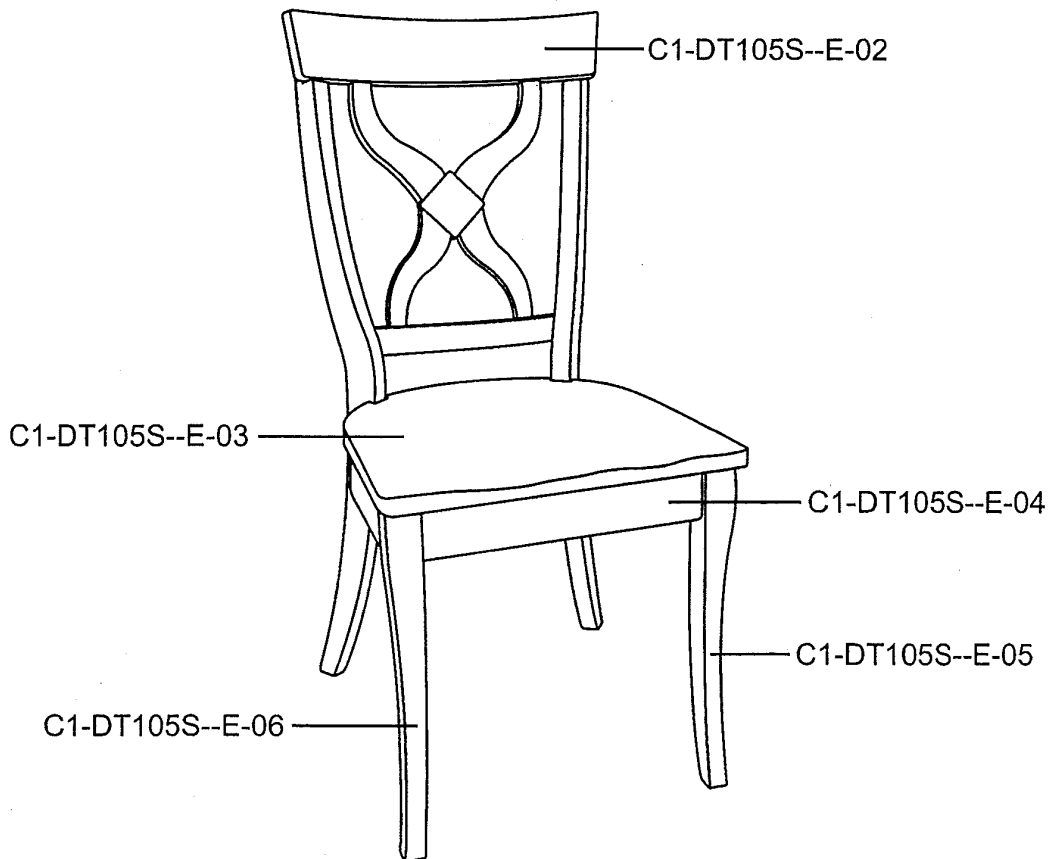



PART NO	FIGURE	DESCRIPTION	Q'TY
C1-DT105S--E-01		Hardware Bag	1 Pce
C1-DT105S--E-02		Chair Back	1 Pce
C1-DT105S--E-03		Cushion seat	1 Pce
C1-DT105S--E-04		Seat Frame	1 Pce
C1-DT105S--E-05		Front Leg (Right)	1 Pce
C1-DT105S--E-06		Front Leg (Left)	1 Pce



Assembly Instructions

C1-DT105S--E
SLAT BACK SIDE CHAIR

HARDWARE PARTS :

					
Wood Screw 4 pcs	(Short) JCBC Bolt 4 pcs	(Long) JCBC Bolt 4 pcs	Lock Washer 8 pcs	Flat Washer 8 pcs	Allen Key 1 pce

ASSEMBLY:

- Position the chair back on a soft surface such as a carpet. Place the chair apron frame on to the chair back. Make sure that the screw holes on the apron frame are facing down.
 - Insert the **JCBC Bolt (Short)** through a **Lock Washer** and a **Flat Washer** into the pre-drilled holes on the apron frame to the pre-drilled holes on the chair back.
- Insert the **JCBC Bolt (Long)** through a **Lock Washer**, a **Flat Washer** and the pre-drilled holes of corner block into the pre-drilled holes on the front leg, tighten the **JCBC Bolt** with **Allen Key** provided.

STEP 1

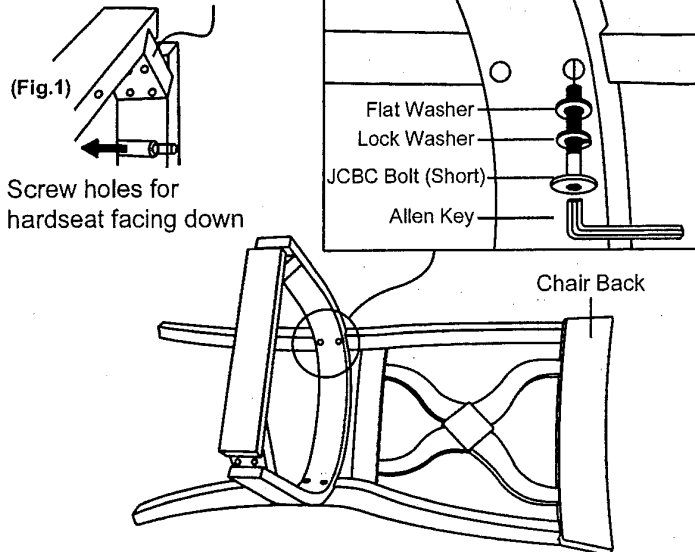

STEP 2

Assemble front leg as shown.

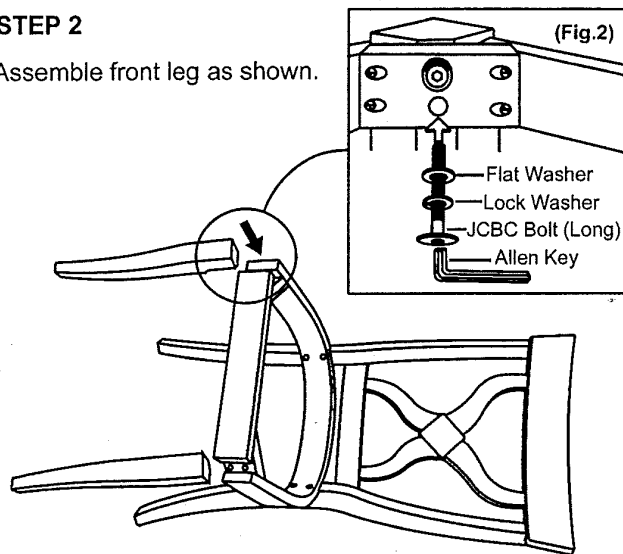

STEP 3

Flip chair upside down and secure the hardseat with the **Wood Screw** through the pre-drilled holes on the apron frame.

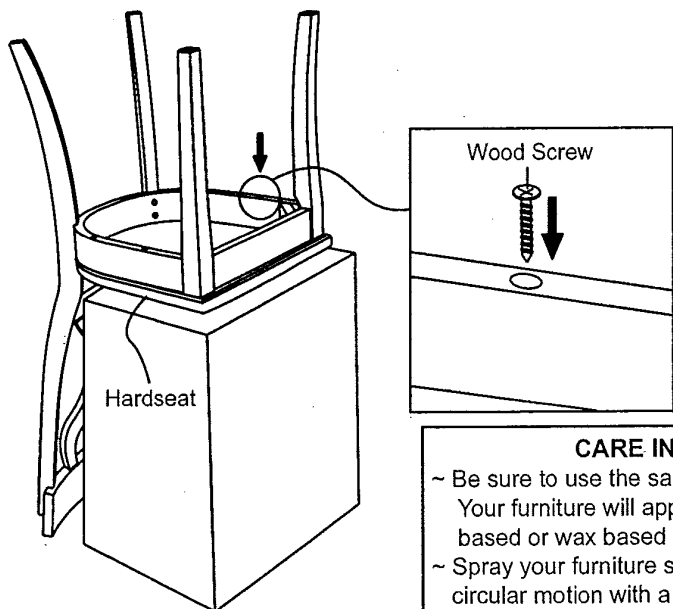

STEP 4

Turn the chair upright. Check its balance and tighten all screws and bolts to complete the assembly.

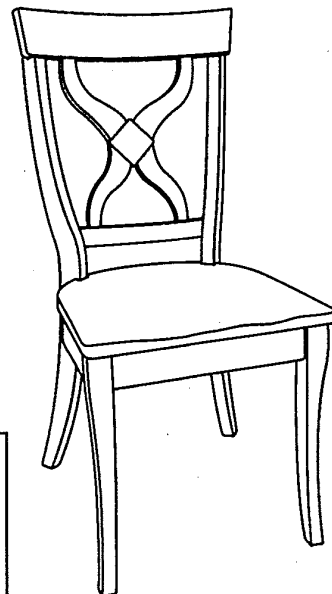

CARE INSTRUCTION

- ~ Be sure to use the same type of polish consistently. Your furniture will appear cloudy or streaky if oil based or wax based polishes are interchanged.
- ~ Spray your furniture surface evenly. Wipe in a circular motion with a soft clean cloth.