

Thank You for purchasing this quality product. Be sure to check all packing material carefully for small parts, which may have come loose inside the carton during shipment. Identify and count all parts and compare with the parts lists below.

ASSEMBLY INSTRUCTION

RIFTON SIDE CHAIR

MODEL: C1-RF102S --O

SIZE : 18 1/2" x 22" X 39"H

Step 1

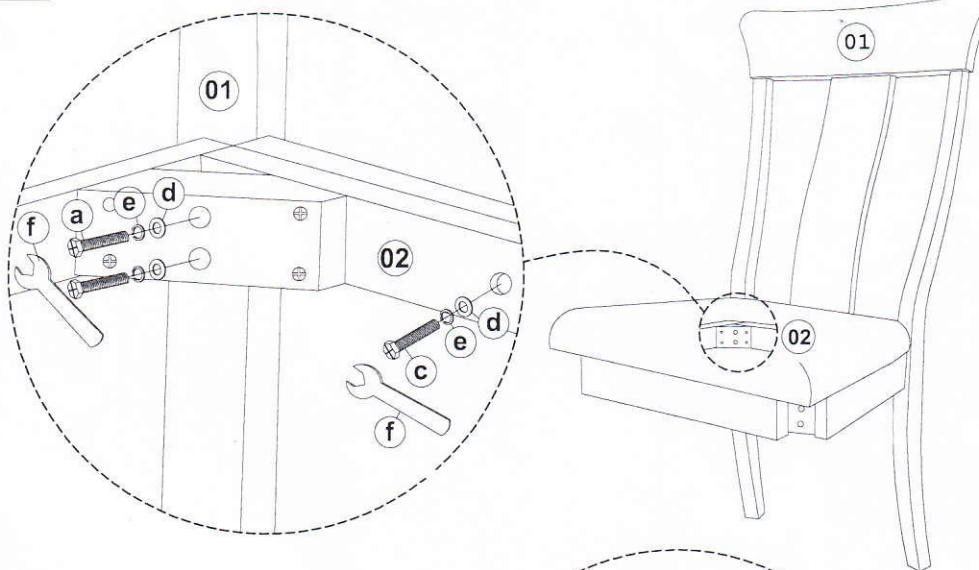

List of Part For 1 Set

Code	Figure	Part	Qty.
01		Chair Back	1
02		Seat	1
03		Front Leg (R)	1
04		Front Leg (L)	1
05		Stretcher (R)	1
06		Stretcher (L)	1

List of hardware For 1 Set

Code	Figure	Hardware	Qty.
a		Hex. Bolt M6 x 80mm	4
b		Hex. Bolt M6 x 60mm	4
c		Hex. Bolt M6 x 40mm	2
d		Flat Washer 1/4" x 18 mm	10
e		Spring Washer 1/4"	10
f		Spanner 10 mm	1
g		PHCB Screw #8 x 1 1/2"	4

Step 2

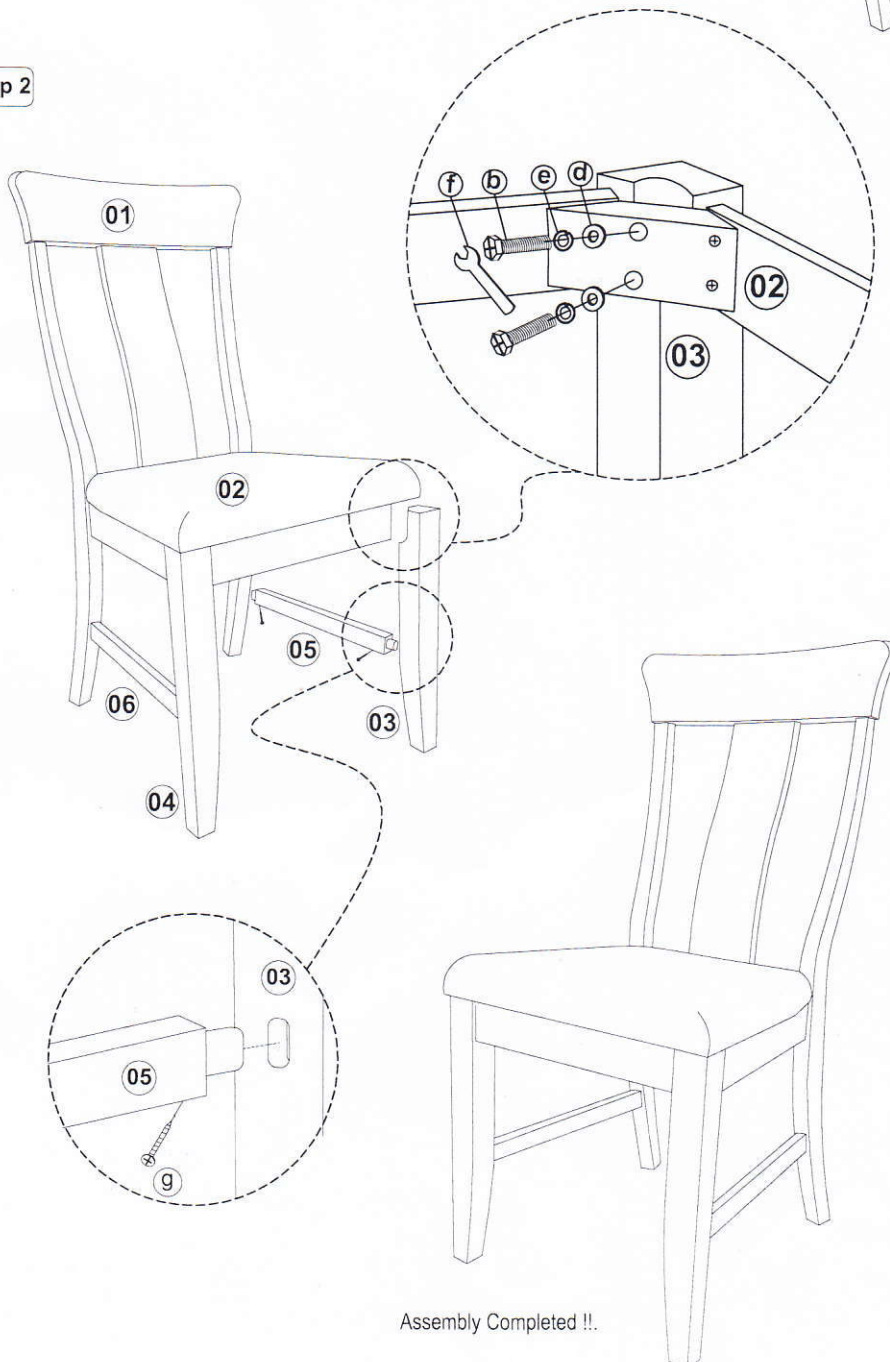

Assembly Completed !!

! Important Notes

- * Keep all hardware parts out of reach of children.
- * Must tighten screws periodically. With use screws will become loose. Check tightness of all screws every 6-8 weeks.
- * Don't attempt to repair or modify parts that are broken or defective. Please contact the store immediately.
- * Do not tighten all screw / bolt until all completely assembled.

Care And Maintenance

- * The Touch of a soft cloth is all the maintenance your wood pieces will ever need.
- * Never use harsh chemicals or abrasive cleaner as they could mark or destroy finish.