

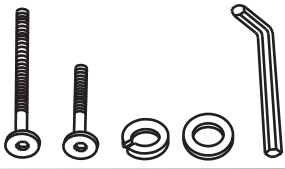

# Assembly Instructions

## C1-SF450S-X LADDERBACK SIDE CHAIR

### PARTS LIST

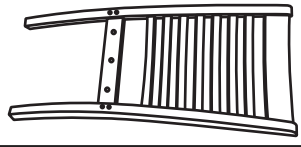

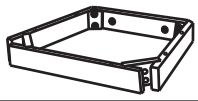
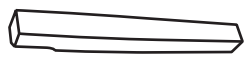
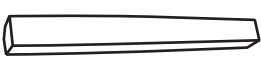
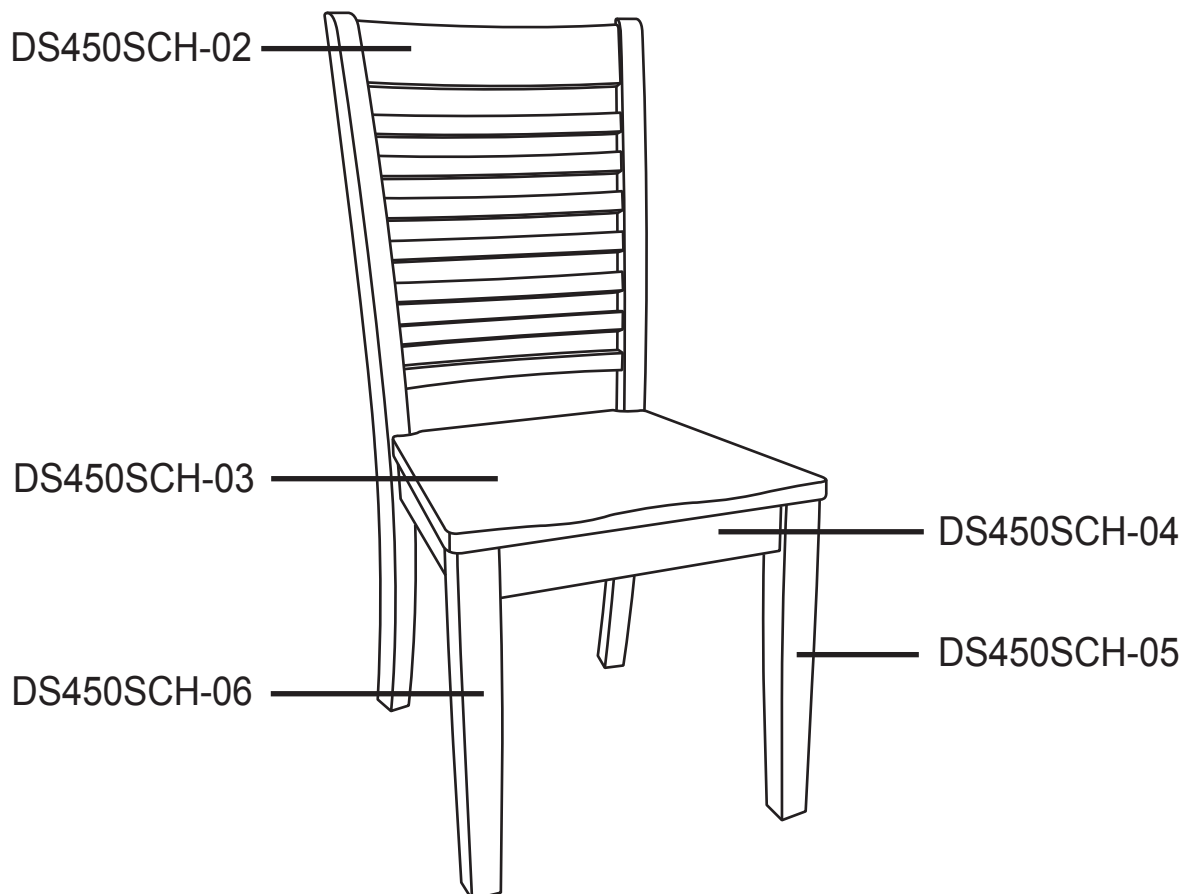

PART NO	FIGURE	DESCRIPTION	Q'TY
DS450SCH-01		HARDWARE BAG	1 Pce
DS450SCH-02		CHAIR BACK	1 Pce
DS450SCH-03		WOOD SEAT	1 Pce
DS450SCH-04		SEAT FRAME	1 Pce
DS450SCH-05		FRONT LEG (RIGHT)	1 Pce
DS450SCH-06		FRONT LEG (LEFT)	1 Pce



# Assembly Instructions

## C1-SF450S-X LADDERBACK SIDE CHAIR

### Hardware List :

 M6x40mm JCBC Bolt 2 Pcs	 M6x70mm JCBC Bolt 8 Pcs	 M6x13mm Lock Washer 10 Pcs	 M6.5x16.5mm Flat Washer 10 Pcs	 Allen Key 1 Pce
---	--	---	---	---

### ASSEMBLY:

1. Position the Chair Back on a soft surface such as a carpet. Place the Seat Frame (Wood seat is pre- attached to the seat frame in assembly) on to the middle rail of the Chair Back with the dowel fully Inserted into the pre-drilled hole.
  - 1.1. Insert 70mm JCBC Bolt a Lock Washer and a Flat Washer into the pre- drilled holes on the rear corner block of the seat frame.
  - 1.2. Insert the 40mm JCBC Bolt a Lock Washer and a Flat Washer through the rear pre-drilled holes on the seat frame.
2. Insert the 70mm JCBC Bolt through a Lock Washer, a Flat Washer and the pre-drilled holes of Corner Block into the pre-drilled holes on the Front Leg, use the provided Allen Key. But do not fully tighten the bolts yet.

(STEP 1)

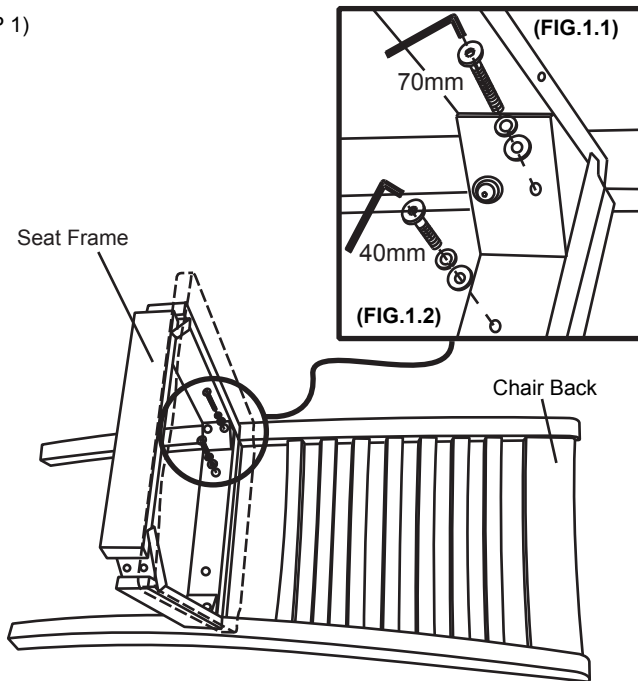

(STEP 2)

Assemble front leg as shown

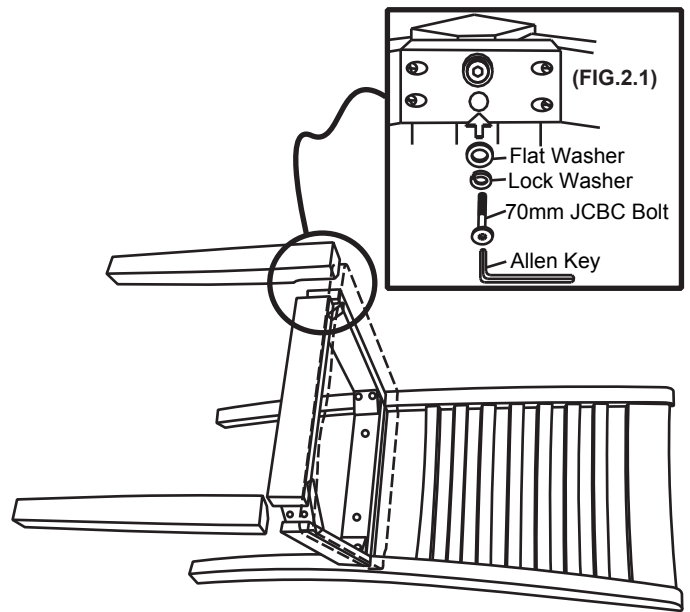

(STEP 3)

Turn the chair to standing position. Check it's balance and tighten all screw and bolts to complete the assembly.

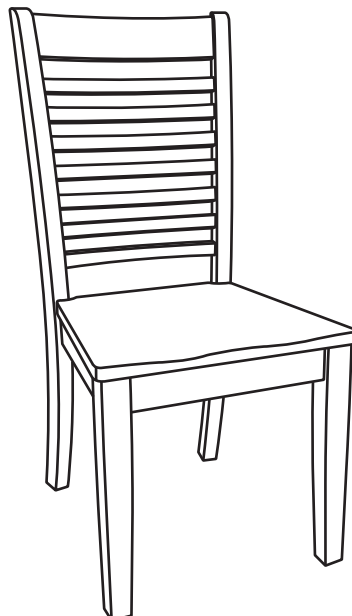

### IMPORTANT NOTE :

~ Please keep all hardware out of the reach of children.

### CARE INSTRUCTION

~ Be sure to use the same type of polish consistently. Your furniture will appear cloudy or streaky if oil based or wax based polishes are interchanged.  
~ Spray your furniture surface evenly. Wipe in a circular motion with a soft clean cloth.