

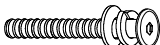

# ASSEMBLY INSTRUCTIONS

MODEL : C1-WD101S- -O

**IMPORTANT NOTE :**

- \* PLACE ALL WOODEN PARTS ON A CLEAN AND SMOOTH SURFACE SUCH AS A RUG OR CARPET TO AVOID THE PARTS FROM BEING SCRATCHED.
- \* BEFORE YOU BEGIN, KINDLY FOLLOW THE ASSEMBLY INSTRUCTIONS STEP BY STEP.
- \* DO NOT TIGHTEN ALL SCREWS UNTIL THE CHAIR IS FULLY SET-UP.

HARDWARE LIST		PART LIST			
A	JCBC M6 x 50mm + S/W M6 + F/W M6 x 13mm 	6PCS	1	BACK REST	1PC
			2	FRONT LEG	1PC
B	ALLEN KEY M4 	1PC	3	SIDE STRETCHER (L/R)	2PCS
C	FH SCREW #8 x 32mm 	8PCS	4	CUSHION SEAT	1PC
			5	SIDE RAIL (L/R)	2PCS

**CAUTIONS :**

(1) DO NOT FULLY-TIGHTEN THE NUT OR NUT BOLTS INITIALLY UNTIL ALL NUTS OR BOLT IS READY ASSEMBLED.

(TO AVOID CAUSING DAMAGES TO THE THREAD, DO NOT OVER-TIGHTEN THE NUTS OR BOLTS.)

(2) KEEP ALL HARDWARE PART OUT OF REACH OF CHILDREN.

**STEP 1**

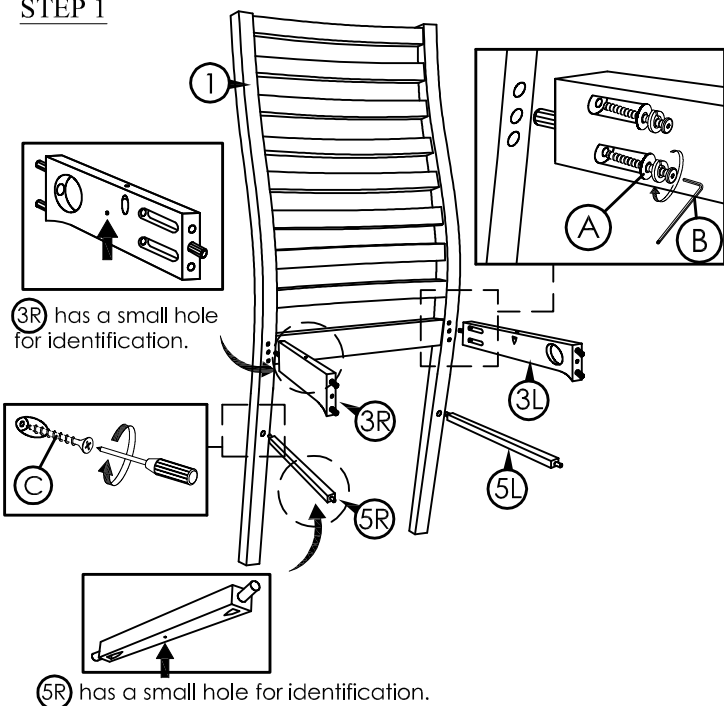

**STEP 2**

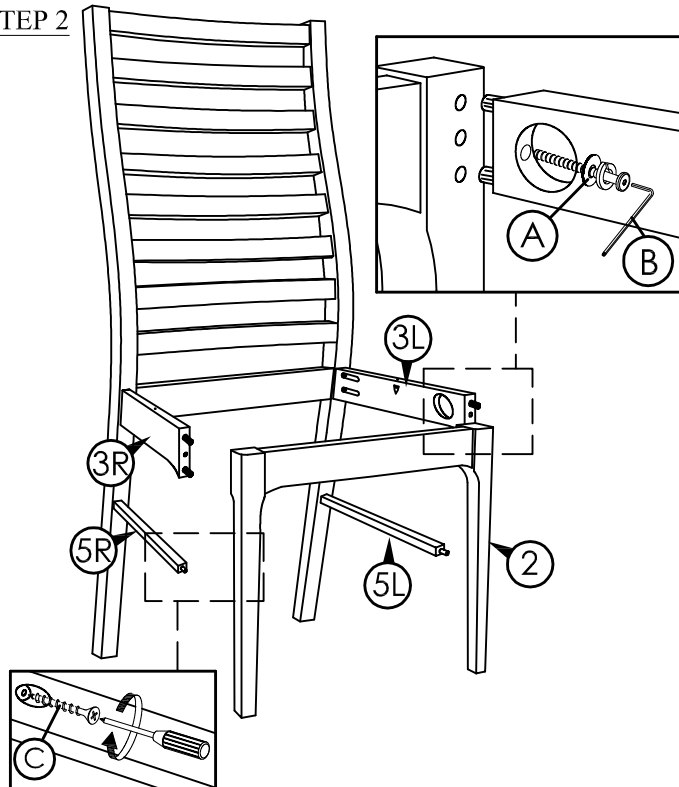

**STEP 3**

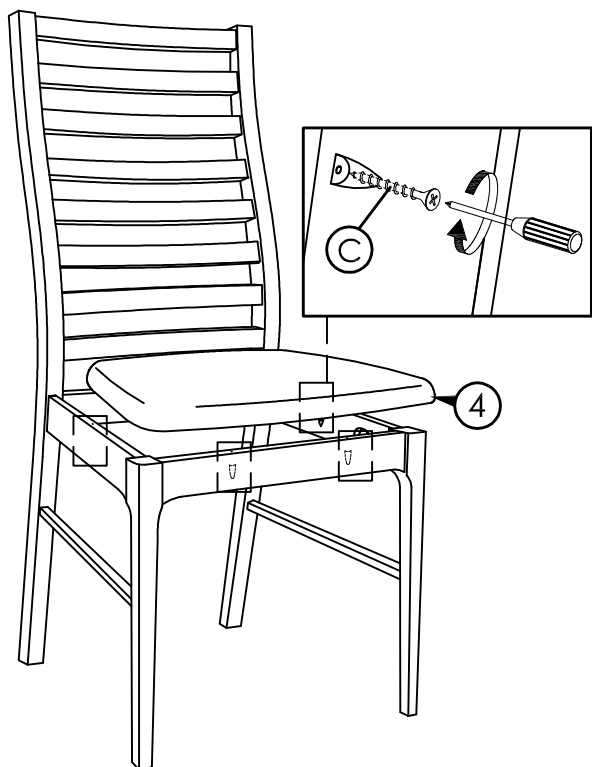

**STEP 4**

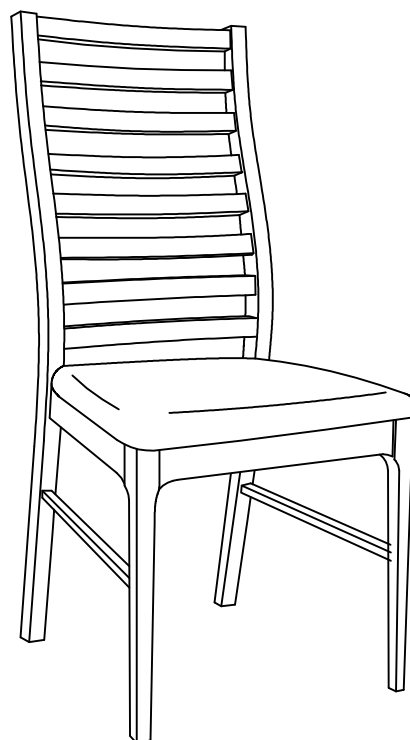

COMPLETED CHAIR ASSEMBLY.