

# Assembly Instruction

T1-DF3648-E, -F, and -X  
RECT. SOLID FIXED TOP TABLE

## PARTS LIST

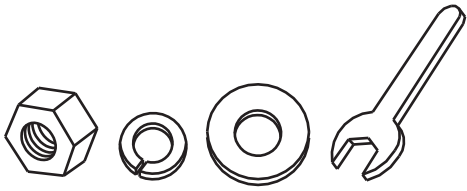
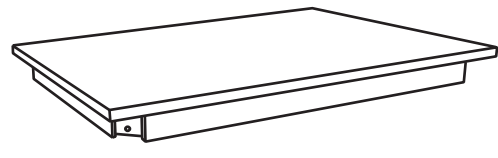
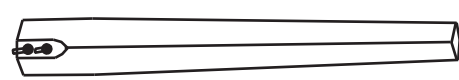
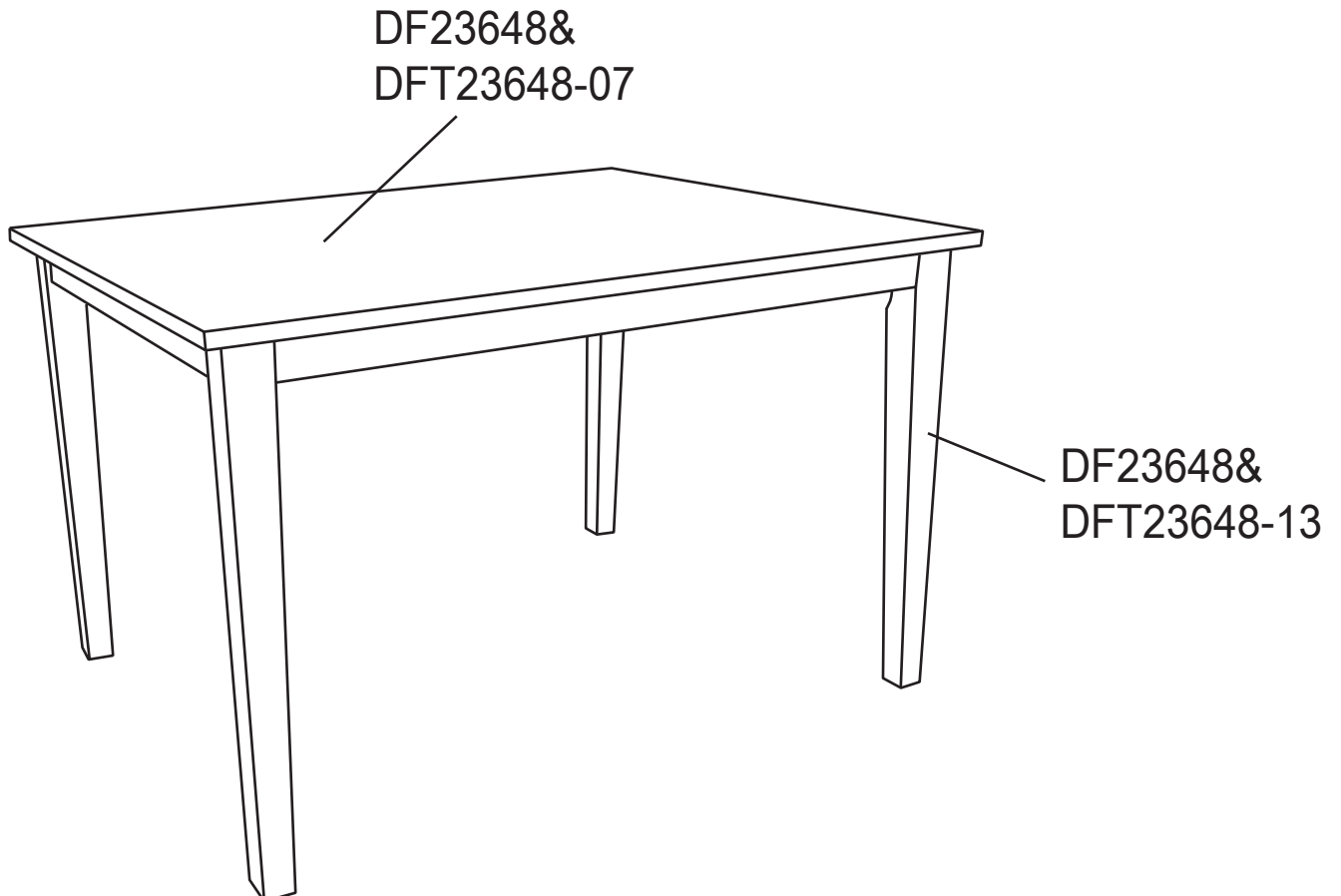

PART NO	FIGURE	DESCRIPTION	Q'TY
DF23648& DFT23648-01		HARDWARE BAG	1 Pce
DF23648& DFT23648-07		TABLE TOP	1 Pce
DF23648& DFT23648-13		LEG	4 Pcs



# Assembly Instruction

T1-DF3648-E, -F, and -X  
RECT. SOLID FIXED TOP TABLE

## HARDWARE PART:

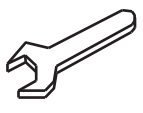
			
NUT 8 pcs	LOCK WASHER 8 pcs	FLAT WASHER 8 pcs	WRENCH 1 pc

NOTE: THIS UNIT SHOULD BE ASSEMBLED BY 2 OR MORE PEOPLE.

### STEP 1

TURN THE TABLE TOP UPSIDE DOWN ON A PROTECTIVE SURFACE SUCH AS CARPET OR OTHER SOFT MATERIAL. PLACE THE LEG TO THE CORNER OF THE APRON, THEN TIGHTEN THE **FLAT WASHER**, **LOCK WASHER** AND **NUT** USING THE **WRENCH** PROVIDED. REPEAT THE SAME FOR THE OTHER LEGS.

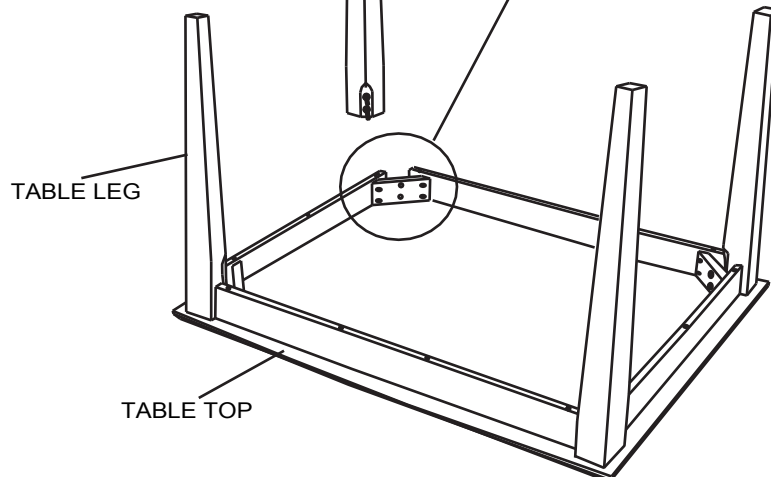
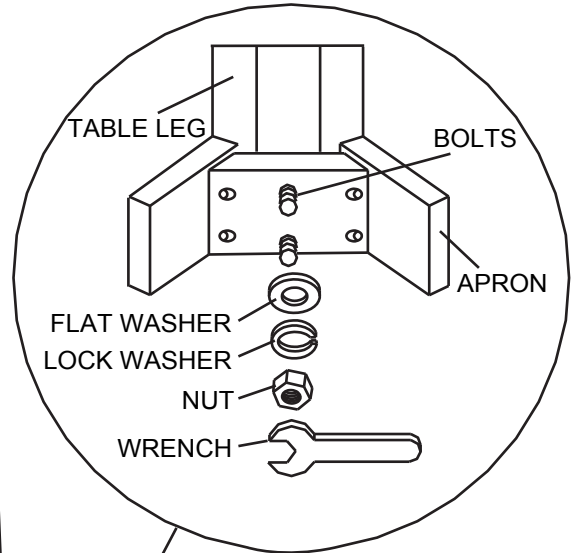

### STEP 2

SET TABLE UPRIGHT ON ITS LEGS.



### CARE INSTRUCTION

- ~ Be sure to use the same type of polish consistently. Your furniture will appear cloudy or streaky if oil based or wax based polishes are interchanged.
- ~ Spray your furniture surface evenly. Wipe in a circular motion with a soft clean cloth.