

WINNERS ONLY®

ASSEMBLY INSTRUCTIONS

PROD.NO : T5-BW3636 - -O

Thank you for purchasing this quality product . Be sure to check all packaging material carefully for small parts that may have come loose inside the carton during shipment .

Components List :

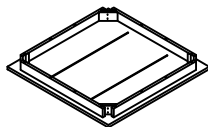
A. Table Top  1pc

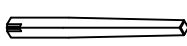
B. Legs  4pcs

Hardware List :

1. Wrench  1pc

2. Hex-Nut  8pcs

3. Spring Washer  8pcs

4. Flat Washer  8pcs

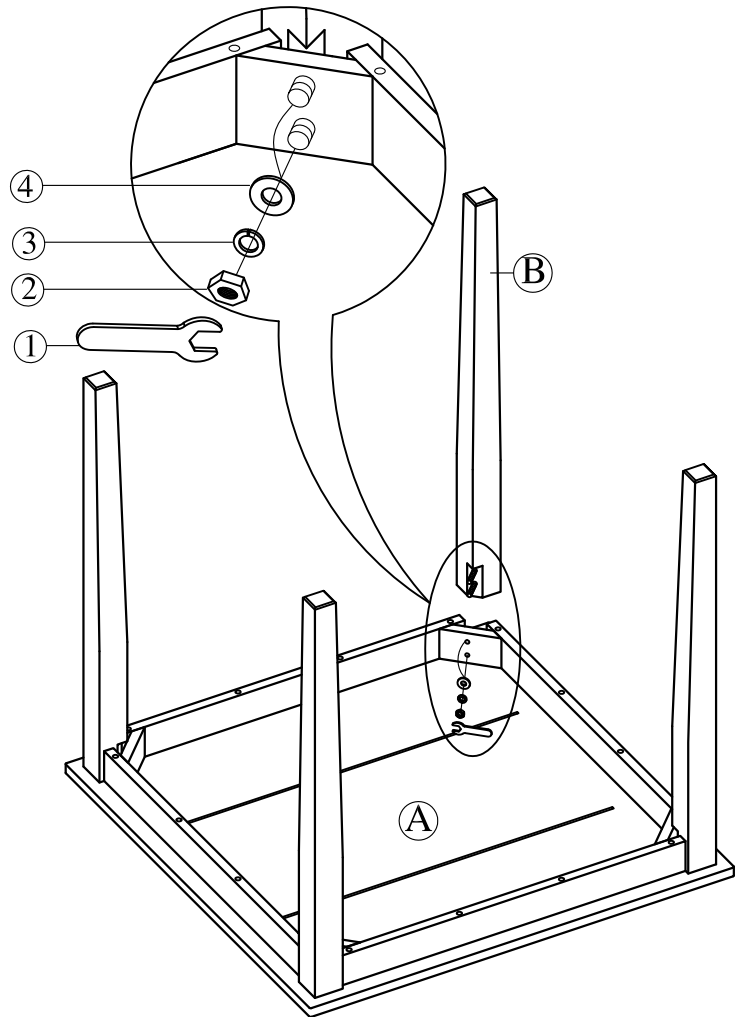

Reminders

1. Use only the hardware supplied.
2. Do not over-tighten bolts.
3. This item may require periodic tightening.

NOTE : Hardware pack is located on back of table Top (A)

Step1: Unpack carton on a smooth clean non-abrasive surface and inventory parts.

Step2: Attach the 4 pcs legs (B) to table top (A) by using flat washer (4) & spring washer (3) and hex-nut (2).

Step3: Carefully turn table upright.

Assembly is now complete
Thank you for choosing it

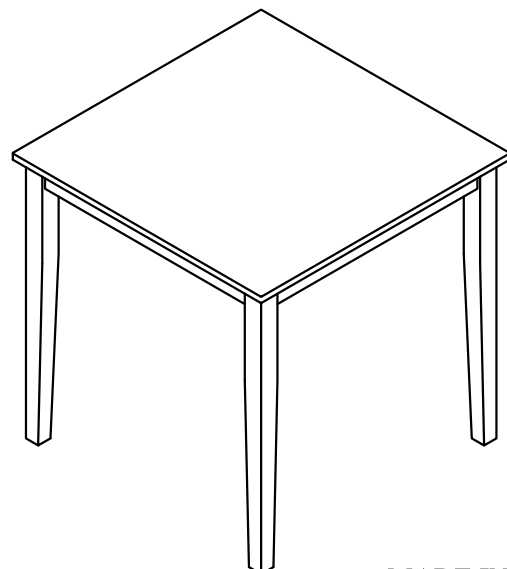

MADE IN VIETNAM

WINNERS ONLY®

ASSEMBLY INSTRUCTIONS

PROD.NO : TS-BW3636 - -O







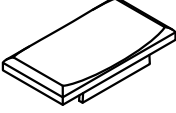
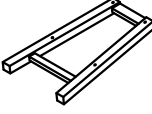
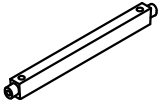

Thank you for purchasing this quality product . Be sure to check all packaging material carefully for small parts that may have come loose inside the carton during shipment .

"Hardware is attached underneath the seat bottom"

Components List :

- | | | |
|---------------|---|------|
| A. Seat Board |  | 1pc |
| B. Leg Frame |  | 2pcs |
| C. Stretcher |  | 2pcs |

Hardware List :

- | | | |
|---|---|------|
| 1. Flat Washer $\phi 12.5 \times \phi 1/4"$ |  | 4pcs |
| 2. Spring Washer $\phi 13 \times \phi 1/4"$ |  | 4pcs |
| 3. Bolt $\phi 1/4" \times 57$ |  | 4pcs |
| 4. Cross Plug $\phi 1/4" \times \phi 9 \times 13$ |  | 4pcs |
| 5. Wood Plug $\phi 13 \times 7$ |  | 4pcs |
| 6. Allen Key 4x57mm |  | 1pc |
| 7. Wood Screw $\phi 8 \times 45 \text{mm}$ |  | 4pcs |
| 8. Glue $\phi 22 \times 52 \text{mm}$ |  | 1pc |

Reminders

1. Use only the hardware supplied.
2. Once the chair is finished, level and tighten all the bolts.
3. Do not over-tighten bolts.
4. This item may require periodic tightening.

NOTE : Hardware pack is located underneath the seat board (A)

Step1: - Place the wood seat (A) upside down on floor with soft surface to prevent finish from scratching.

- Attach L/R leg frame (B) to the apron pre-attached on wood seat (A). Put the cross plug (4) into hole on apron. Insert bolt (3) with spring washer (2) flat washer (1) through the holes on L/R leg frame. (secure but do not tighten all bolts on this step).

Step2: - Insert side stretcher (with using glue (8) on stretcher dowel) into L/R leg frame (B). secure with wood screw (7) by using phillip head-screw driver (not provide).

- Tighten all bolts (3) with allen key (6) after leveling the chair.
- Using wood plug (5) fill onto the hote on L/R leg frame.

Assembly is now complete

Thank you for choosing this product.

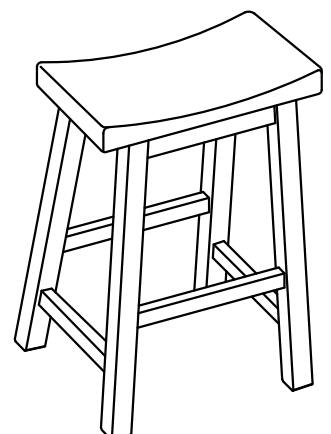
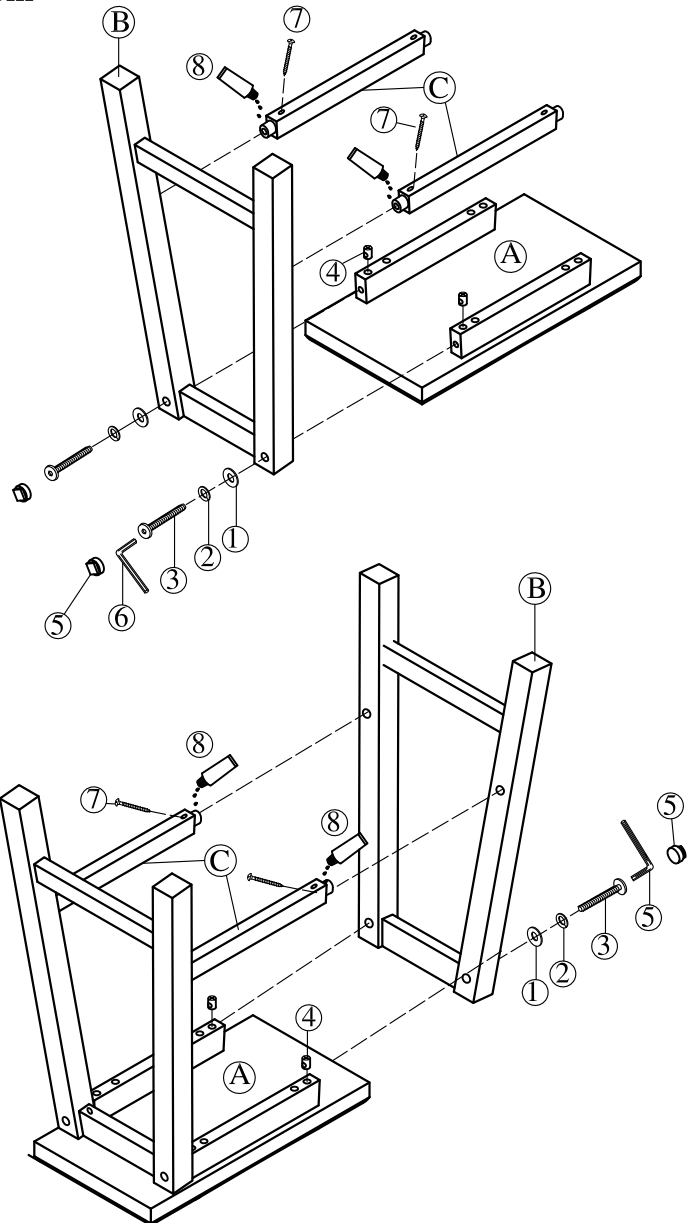

MADE IN VIETNAM